

FOR INSTALLATION ENGINEERS



installation instructions [en] Stûv 16-cube & Stûv 16H

05-2013 – SN 97951 > ...

This Stûv stove has been designed to offer you maximum comfort and safety. It has been manufactured with the greatest of care. If however you should find the slightest dissatisfaction with it, please contact your supplier.

We recommend that you read these instructions prior to installation.

Some configurations might have an impact on the sequence of operations to be performed.

Contents

PRESENTATION OF THE PRODUCT	4
Standards, certification and technical characteristics	4
Dimensions	5
Overview	6
Recommandations	6
PREPARATION OF THE AREA	7
Air inlets – the various configurations	7
Combustion air inlet	8
Smoke flue	9
The stove's surroundings and decoration	9
Safety	9
Tools	10
INSTALLATION	11
On taking delivery of the equipment	11
Unpacking	11
The support plate	13
Mounting the plate on the base to form an Stûv 16 H	13
Fitting the Stûv 16-Up bracket	13
Assembly of the plate on the ventilation chamber	14
Assembly of the plate on the ventilation chamber	15
Combustion air connection	16
Fan kit	17
Assembly of the fan on the base plate	17
Electrical connections	17
Closing the fan's cover	19
Positioning of the stove	20
Connection to the smoke flue	21
Assembly of the thermal switch	21
Installation of the panel	22
Refitting the door	22
Graduated tablet	23
When the installation of the stove is complete...	23
ACCEPTANCE OF WORKS	25

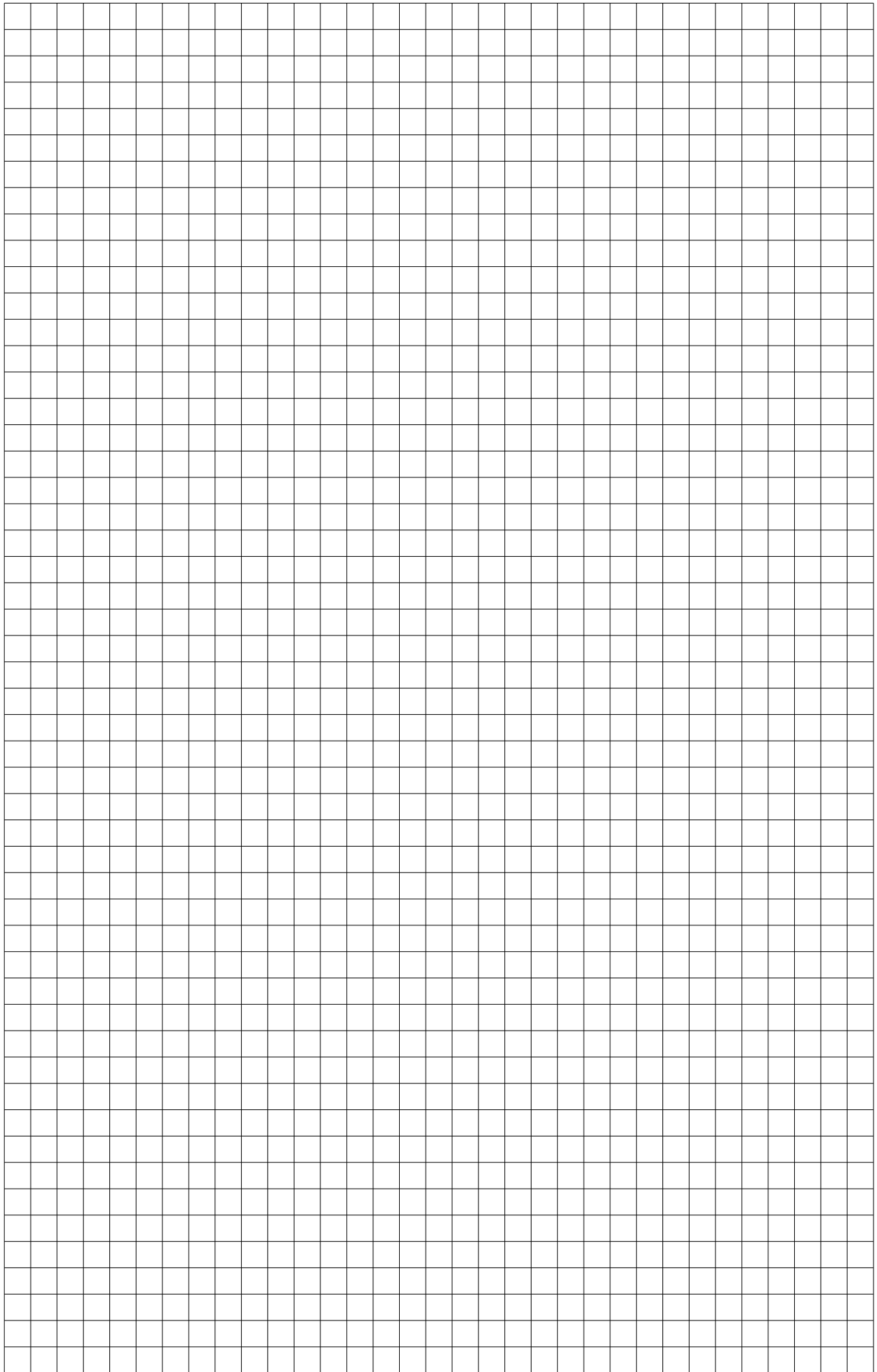

PRESENTATION OF THE PRODUCT

Standards, certification and technical characteristics

The Stûv 16-cube stoves (for intermittent operation) comply with the requirements of EN European Standards in terms of efficiency, gas emissions, safety etc....

Data provided in this notice are supplied by a certified laboratory.



Test results according to EN 13240 : 2001 and 13240-A2 : 2004 standards (stoves)



Stûv sa
B-5170 Bois-de-Villers (Belgium)

10 QA 101322906
EN 13240 : 2001 / A2 : 2004

Wood stove **Stûv 16/58-cube**

Minimum safety distance from adjacent combustible materials :

- behind : 10 cm*
- on the sides : 15 cm
- below : 0 cm

Recommended fuel : wood logs only

CO emissions : < 0.09%

Average smoke temperature at rated power : 283°C

Nominal heat power : 8 kW

Efficiency : 80%

Particle emissions : 73 mg/Nm³

Please read the installation instructions and directions for use !

* 16/58-Up = 5cm



Stûv sa
B-5170 Bois-de-Villers (Belgium)

10 QA 101322906
EN 13240 : 2001 / A2 : 2004

Wood stove **Stûv 16/68-cube**

Minimum safety distance from adjacent combustible materials :

- behind : 10 cm*
- on the sides : 15 cm
- below : 0 cm

Recommended fuel : wood logs only

CO emissions : < 0.09%

Average smoke temperature at rated power : 330°C

Nominal heat power : 9 kW

Efficiency : 77%

Particle emissions : 72 mg/Nm³

Please read the installation instructions and directions for use !

* 16/68-Up = 5cm



Stûv sa
B-5170 Bois-de-Villers (Belgium)

10 QA 101322906
EN 13240 : 2001 / A2 : 2004

Wood stove **Stûv 16/78-cube**

Minimum safety distance from adjacent combustible materials :

- behind : 10 cm*
- on the sides : 15 cm
- below : 0 cm

Recommended fuel : wood logs only

CO emissions : < 0.09%

Average smoke temperature at rated power : 378°C

Nominal heat power : 10 kW

Efficiency : 75%

Particle emissions : 70 mg/Nm³

Please read the installation instructions and directions for use !

* 16/78-Up = 7cm

Other technical characteristics

	Stûv 16/58-cube	Stûv 16/68-cube	Stûv 16/78-cube
Minimum draught needed to obtain the rated calorific output	12 Pa	12 Pa	12 Pa
Weight-flow ratio of smokes	5.7 g/s	6.6 g/s	7.4 g/s
Average smoke temperature at rated power	283°C	330°C	378°C
Minimum diameter of the duct for the intake of outside combustion air	63 mm	63 mm	63 mm
Optimum output range for usage	6–9 kW	7–11 kW	8–12 kW
Range of wood consumption per hour recommended (at 12% humidity)	1.7–2.5 kg	2.0–3.2 kg	2.4–3.6 kg
Maximum limit for consumption of wood per hour (to avoid overheating the system)	3.4 kg/h	4.1 kg/h	4.6 kg/h
Maximum length of logs in horizontal position	40 cm	50 cm	60 cm
System mass Stûv 16-cube	105 kg	113 kg	121 kg
System mass Stûv 16-H	136 kg	147 kg	158 kg
Weight of Stûv 16-up stove	113 kg	122 kg	130 kg

Dimensions

Stûv 16-cube without fan

Stûv 16-cube with fan

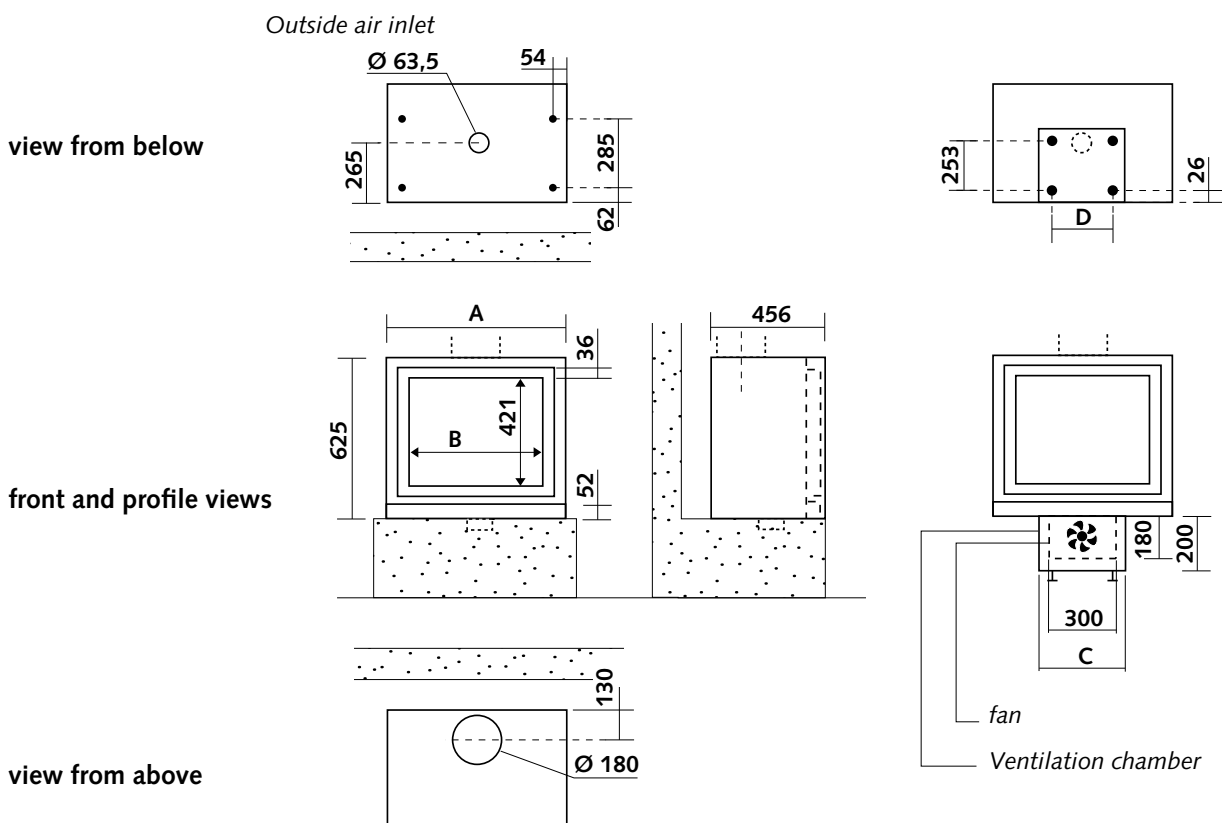

	A	B	C	D
Stûv 16/58-cube	580	448	340	288
Stûv 16/68-cube	680	548	540	512
Stûv 16/78-cube	780	648	540	512

Overview

Included with the stove (basic)

- [1] fireplace
- [2] support plate
- [3] cable outlet

Option

- [4] Outside air intake kit: Flue outlet + Ø 63 mm flexible tubing (3 m)
- [5] fan
- [6] adjustable support table
- [7] ventilation chamber
- [8] base for stove fitted with a fan, an outside air connection or both. A simpler model is available for stoves without a fan and without an outside air connection.
- [9] Stûv 16-H base

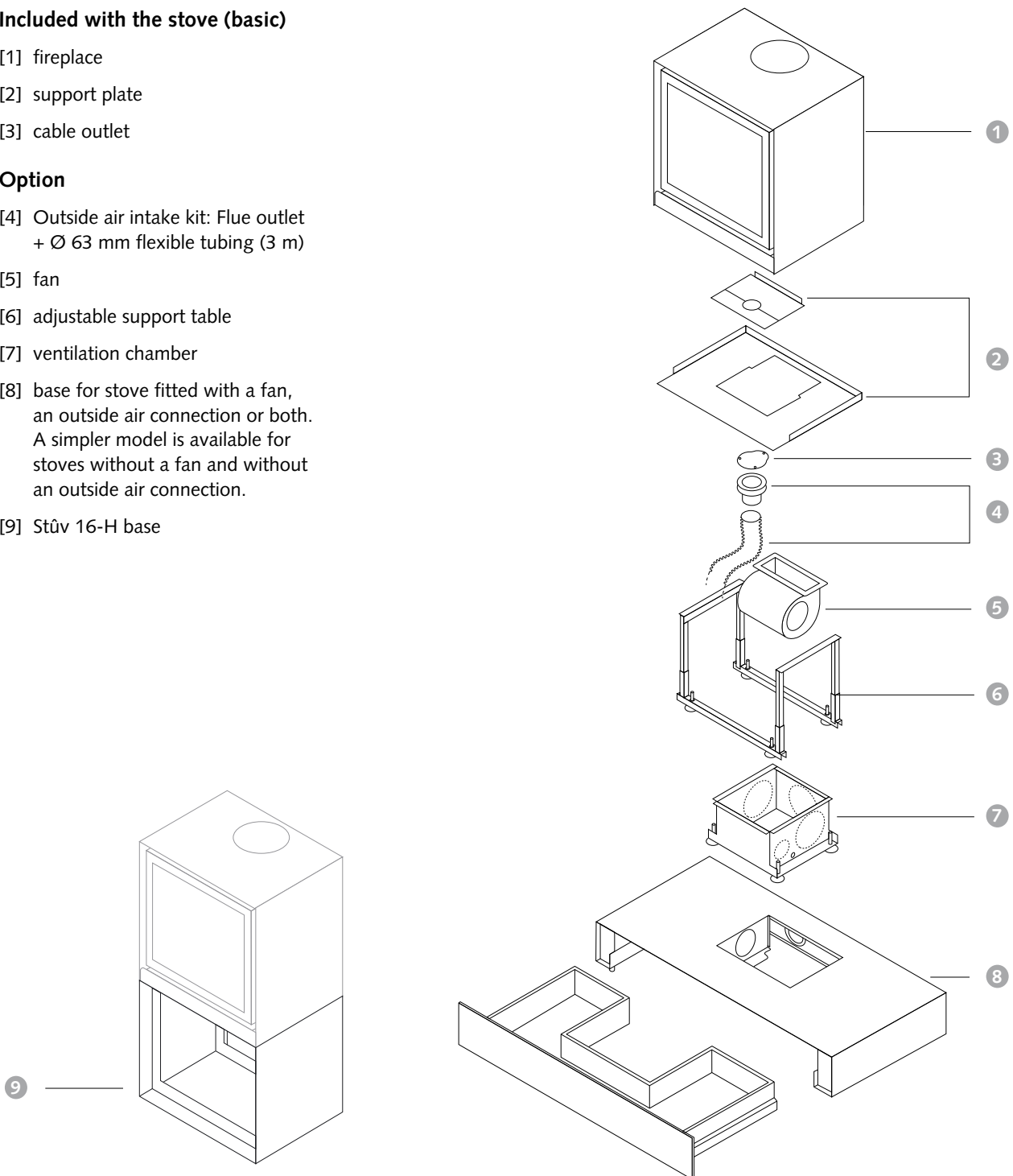

Recommandations

We strongly recommend you entrust the installation of this Stûv to a qualified professional who is able to ensure that the characteristics of the smoke flue correspond to the stove installed.

The installation of the stove, its accessories and surrounding materials must adhere to all regulations (local

and national) and all standards (national and European).

Some national and local regulations require the installation of an access flap in the connection between the stove and the smoke flue.

The stove has to be installed in such a way as to facilitate access to sweep

the stove, the connection duct and the smoke flue.

Any modification made to the system may be dangerous and will invalidate the guarantee.

PREPARATION OF THE AREA

Air inlets – the various configurations

The combustion air is drawn from outside (ideally) or from the room to be heated.

Convection is natural (no fan) or forced (fan).

There are four possible configurations.

Configuration 1

Configuration not compatible with Stûv 16-H and Stûv 16-Up stoves

The stove is equipped with a fan.

The combustion air is drawn from the room where the stove is installed.

Please note: The fan must not disturb the air inlet for combustion.

Configuration 2

Configuration not compatible with Stûv 16-H and Stûv 16-Up stoves

The stove is equipped with a fan.

The combustion air is drawn directly from outside the building.

Configuration 3

Stove without a fan.

The combustion air is drawn directly from outside the building.

Configuration 4

Stove without a fan.

The combustion air is drawn from the room where the stove is installed.

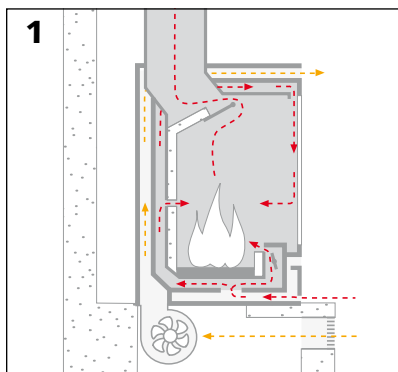

View of the base plate corresponding to each configuration; this is also covered in the "installation" section.

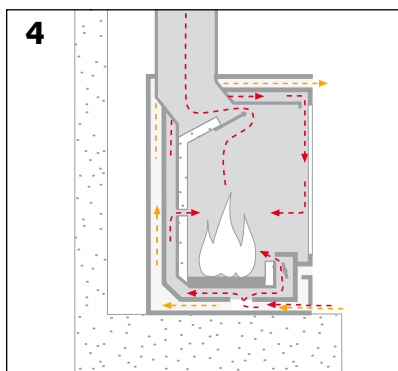
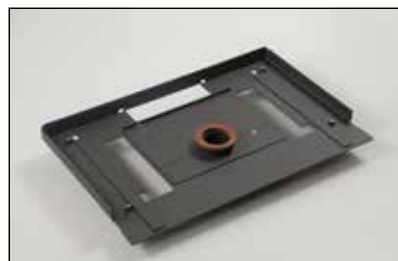
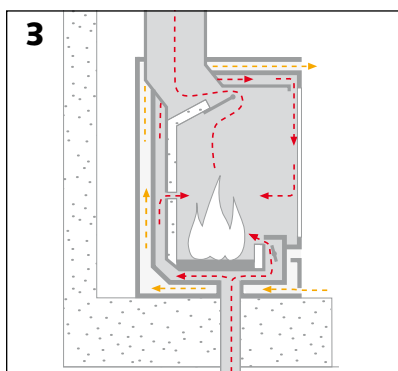
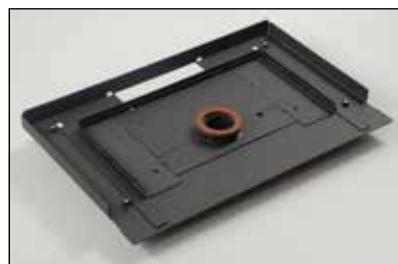
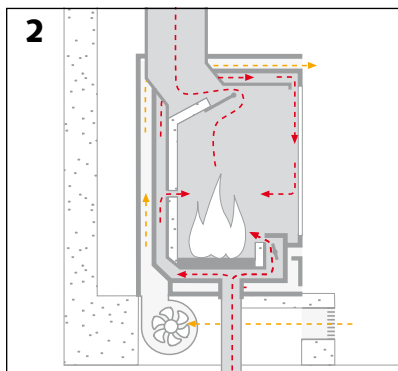

The stove requires air for combustion.

The air is drawn from outside

[diagram 1]

The Stûv 16-cube is designed to be directly connected to an outside air inlet (independent of the air in the house). This configuration - which we recommend - guarantees good operation regardless of the degree of air-tightness in the building or the pressure variations in the house due to a kitchen hood or controlled mechanical ventilation, for example.

This air inlet comes from a ventilated empty space, a ventilated room (cellar) or from outside (mandatory regulation in some countries).

The duct carrying this air...

... will be protected on the outside by a grill [diagram 1] the free passage section of which is at least equivalent to the section of the air inlet: \varnothing 63 mm. Please note that the infiltration of water and the effect of the wind can damage the system.

... will be as short as possible to prevent pressure loss and to prevent making the house cold.

With our flexible standard duct (\varnothing 6.3 cm), we recommend a maximum length of 2 m and no more than 4 bends. If you exceed these guidelines, you must compensate with a greater diameter and/or a smoother duct.

Careful not to crush the flue.

The internal/external valve

It prevents the house from becoming cold when the stove is not in use.

This device is optional if you choose a direct connection to the stove. However, it is interesting if the lengths of the ducts to the stove are too great or installation is carried out in an energy-efficient home.

It should ideally be located as close as possible to the outside wall.

The air is drawn from the room

If the stove is not connected directly to an outside air inlet, a sufficient air inlet (approximately 50 cm²) should ideally be created close to the stove.

Air can be drawn from the room via the inlet at the bottom of the front of the stove [photo 2].

Warning!

Ensure the configuration chosen fully meets local and national regulations.

Be careful with air extraction systems (kitchen hoods, air conditioning, mechanically-controlled ventilation, other stoves) in operation in the same space or in an adjacent room. They also use lots of air and can cause a depression in the room and prevent the stove from operating correctly (risk of draughtback). They can affect the operation of the stove even if it is connected to an outside air inlet.

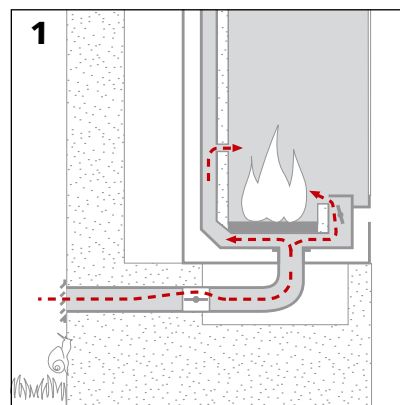

Smoke flue

Ensure the flue's dimensions, the gaps from combustible materials and glass etc. meet local regulations and the applicable installation standards in line with good practice.

Basic information

For good draught, the stove must be suited to the flue (or vice versa).

An oversized flue is as detrimental to the smooth operation of the stove as an undersized flue. At www.stuv.com > **questions – answers** you will find a simplified method for roughly calculating the flue characteristics based on the type of stove. Consult a professional for a more accurate calculation.

The flue should be as straight as possible and insulated to encourage the draught and prevent condensation.

The ideal solution is a flue built inside the building and thermally insulated. An outside flue without any insulation must be avoided.

The stove can only be connected to a smoke flue serving several systems on 3 conditions:

- all the systems connected to this flue use the same fuel,
- they have automatically closing doors like the Stûv 16-cube,

- the flue has been checked for this type of usage; consult a professional if necessary.

Standard diameter of the smoke outlet: 180 mm

Some flue configurations may require a different diameter than that provided as standard. Should this be the case, please consult your retailer.

The stove's surroundings and decoration

If the wall at the back of the stove is made of flammable material (wooden partition, for example) or is covered with flammable material, leave a distance of at least 10 cm between this wall and the back of the stove.

With regard to the Stûv 16-Up, the distances are different. Please refer to the marking information CE P.4. With regard to the distances between the wall and the connecting duct, please refer to local and national regulations.

Space to leave for the fan or for the ventilation chamber

	C	D
Stûv 16/58-cube	350	580
Stûv 16/68-cube	550	680
Stûv 16/78-cube	550	780

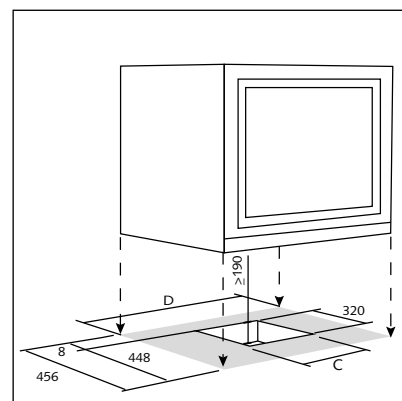

Safety

Holding capacity of the structure

Ensure that the resistance of the floor is sufficiently strong to support the stove and the construction of the cladding. If in any doubt, please consult a specialist.

Radiated heat

Significant heat may be radiated through the glass door. Ensure the materials exposed to this radiated heat are resistant to high temperatures [diagram 1].

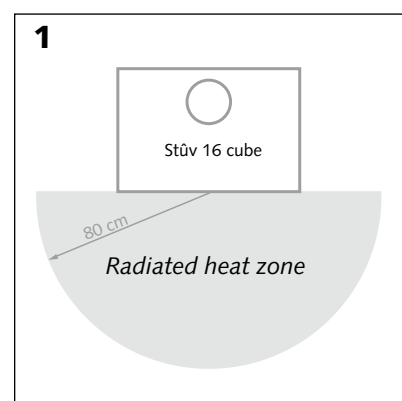

Tools

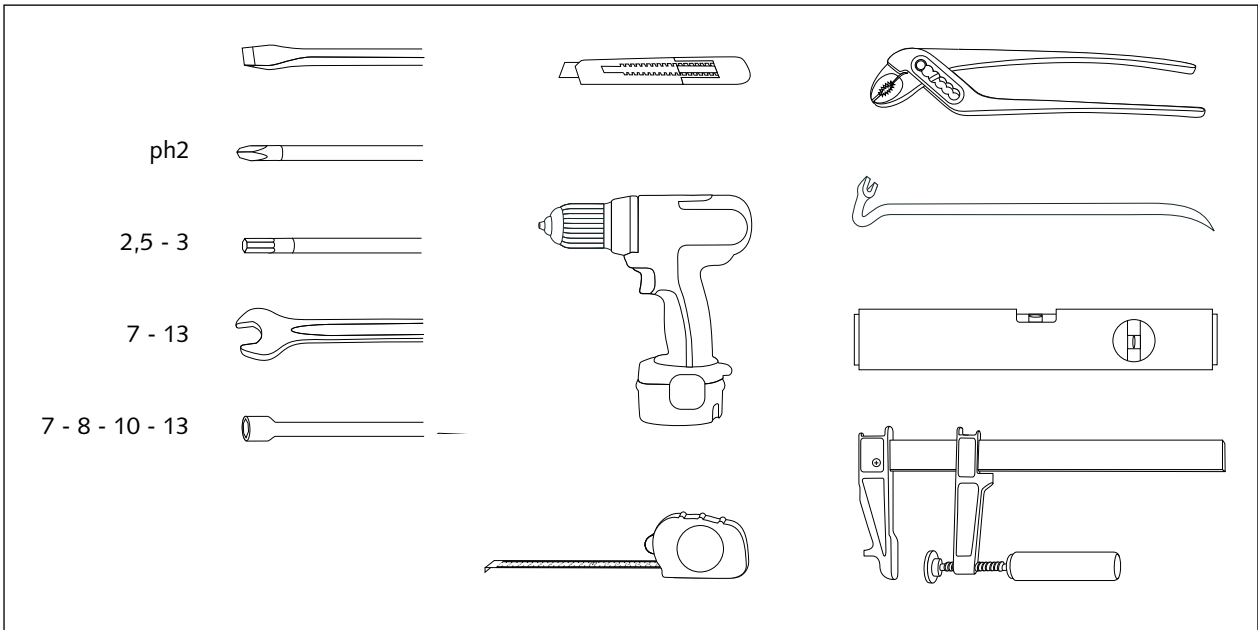

INSTALLATION

On taking delivery of the equipment

Please note!

Upon receipt of this stove, please ensure that the glass door has not been damaged during delivery. The guarantee only covers damage due to transport if it is reported within 48 hours of delivery and it is indicated on the delivery slip [picture 1].

Complaints

Always indicate the serial number visible on the stove when making a complaint [picture 2].



Unpacking

Please note!

The paint is not oven baked and is therefore relatively fragile but will harden after being heated a few times. Handle the system with care when installing.

Checking the order

Where accessories have been ordered (frame, support,...), they will be found around the hearth or its packaging. Please check all accessories are supplied as ordered.

Inside the combustion chamber, you will find...

- [a] Paint spray for touch-up
- [b] grips to handle the finishing cover
- [c] flap
- [d] graduated tablet
- [e] cold handgrip to handle the door and the valve
- [f] anti-sweep stainless steel bar
- [g] 2 bolts for attaching the front of the stove to the support plate

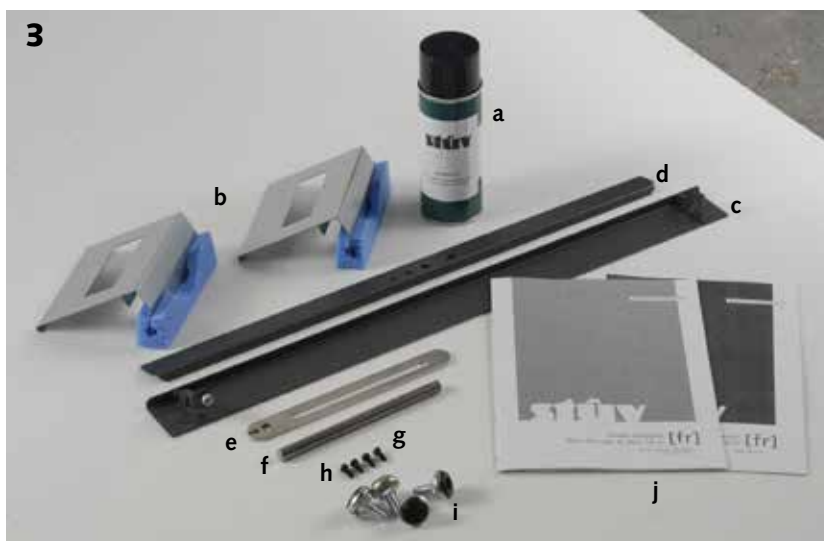

- [h] 2 screws for attaching the back of the stove to the support plate
- [i] adjustable levelling feet
- [j] Installation instructions and directions for use

Before moving the stove

Dismantle the door: unfasten the resisting spring [photo 4], then remove it,

Lift off the cover

- remove the 4 screws on either side of the door [photo 5],
- remove the upper part of the cover from the stove. To do so, release the lock by undoing the hexagonal-headed screw [photo 6] and turn the lock [photo 7],
- take off the cover using the grips provided [photos 8 and 9].

Moving the stove

- using a pallet truck: leave it on its pallet,
- using a hand truck: insert some cardboard to protect the back of the stove, turn the stove onto its back, leave the pallet in its position,
- by hand: take hold of the stove at the front [photo 10] and at the back [photo 11].

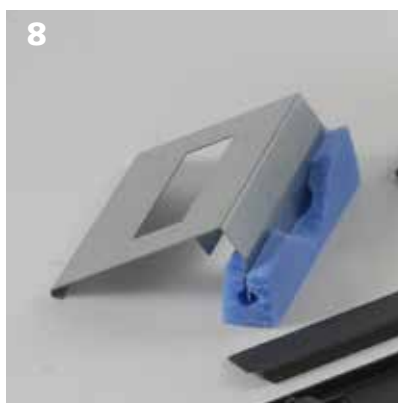
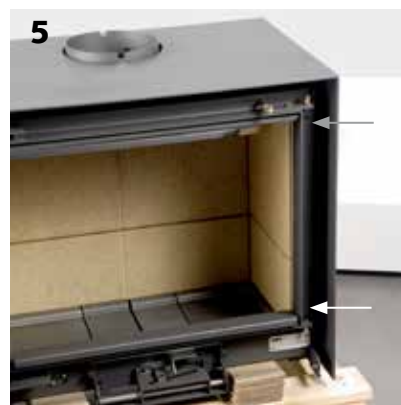

The support plate

The base plate [photo 1] is a key element in the system: the outside air inlet duct is connected to it and the fan and its accessories are attached to it.

It supports the stove itself.
It remains fixed.

It is positioned

- on the ground
- or on a brickwork base
- or on the adjustable support
- or on the ventilation chamber.
- or on a Stûv base,
- or on the "16-cube base" sub-unit to form a Stûv 16-H.

In the two latter cases, see the instructions which come with these accessories.

Whatever solution is chosen, the position of the plate determines the position of the stove.

It is thus essential to align it accurately with the smoke flue. A small hole cut in the sheet metal [photo 2] indicates the verticality of the smoke outlet.

Please bear in mind that the front edge of the plate will stand 8 mm back from flap [photo 3].

Prepare the base plate according to the configuration chosen. See page 7.

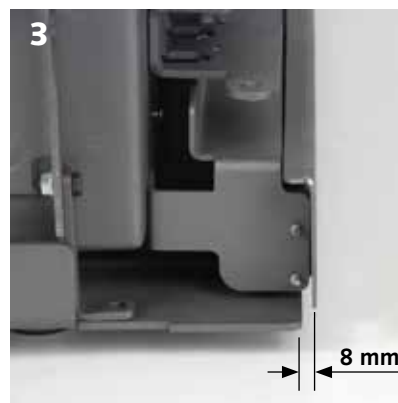
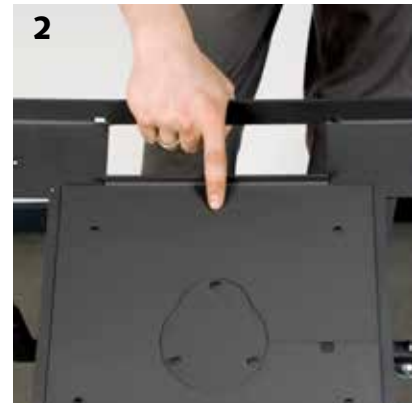
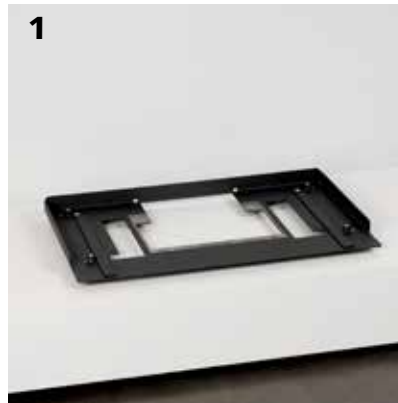

Mounting the plate on the base to form an Stûv 16 H

Consult the instructions supplied with the accessory.

Fitting the Stûv 16-Up bracket

Consult the instructions supplied with the accessory.

Assembly of the plate on the ventilation chamber

Where this option has not been selected, please move on to the next chapter.

The table comprises [picture 1]:

- the pre-fitting plate [a],
- a «left legs» element and a «right legs» element [b],
- a lower front support and a lower rear support [c].

Note that the lower supports are not symmetrical; they must be arranged as shown in [picture 2].

The finished table is 60 cm high. Its legs may be cut back. If, for example, a height of 35 cm is required, legs will have to be cut 25 cm shorter; the table will have a minimum height of 20 cm if the legs are cut 40 cm.

Assemble the legs and lower elements [picture 3]. Note the position of the cross-piece between the legs [picture 4].

After inserting the legs into the lower supports, turn the assembly over and strike it with a hammer to drive the legs fully in and lock the assembly [picture 5].

Fix the left legs (for example) to the plate. Put the 4 M6 X 20 screws with hexagonal heads provided with the stove into the corresponding holes [diagram 7].

You will then have to exert a traction on the right-hand legs to align the holes [picture 8].

Level the table by adjusting height of screw-in legs.

Fix the table to the floor with screws or silicone glue.

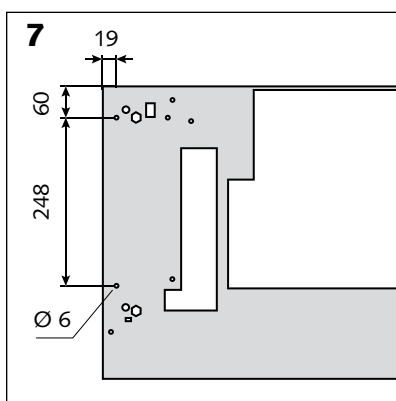

Assembly of the plate on the ventilation chamber

Where this option has not been selected, please move on to the next chapter.

Warning! These components are not compatible with Stûv 16-H and Stûv 16-U configurations.

The ventilation box allows the connection of ducts which feed ambient air from remote areas of the room containing the stove or from adjacent rooms.

The ventilation box is not mandatory: when it is not fitted, the ventilator fan is placed in a space under the stove and will draw nearby ambient air through vents to be provided.

The ventilation box must be screwed on to the plate. It can be fitted in two ways:

- it can serve as a base for the stove.
- suspended from the pre-fitting plate (which is resting on the masonry or on the adjustable support)

The ventilation box supports the stove.

Determine the exact position of the box (which in turn will determine that of the stove !) A cross cut in the bottom of the box is plumb with the centre of the flue.

The front face of the chamber is 134 mm behind the front face of the stove [diagram 1]. The front face does not have pre-cuts for the connection of ducts [photo 2].

Free the openings for the convection ducts (Ø 150mm).

Caution : where this is the selected option, the outside combustion air duct (Ø 63 mm) must also run through the ventilation box [pic. 4 & 8]. Passage through the box : ideally from the bottom or from the left hand side since the electronic power circuit will occupy the right hand side ; if for some reason it has to be on the right hand side, then the electronic circuitry will have to be fitted to the left.

Set level with the adjustable legs [pic. 5].

Secure the box to the floor [pic. 6].

Install the flanges [pic. 7], secure duct with a clamp.

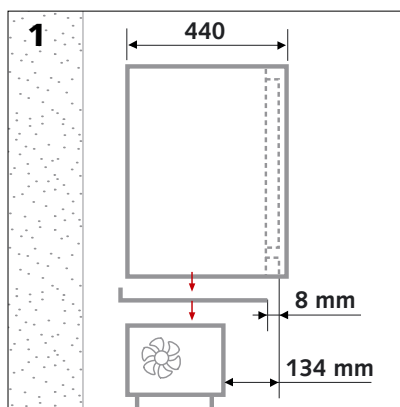

Combustion air connection

Air drawn from outside

If the stove is positioned on a Stûv base with a drawer or on a Stûv 16 H base, please consult the instructions which come with these accessories.

The combustion air is drawn from outside by means of a duct [diagram 1] connected to the support plate.

Remove the plug [photo 2] and the cover at the front [photo 3].

Fit the duct over the sleeve [photo 4] and secure it with a clamp collar [photo 5] with the collar attachment turned towards the back of the stove

Insert the 2 M4 screws with hexagonal heads into the cover at the front, put the sleeve between the 2 screws [photo 6] and then fasten it all.

Ensure the plate is level and attach it to the base [photo 7].

Combustion air is drawn from the room where the stove is installed

Make sure there will be adequate air renewal once the stove is operating.

Remove all of the covers of the support plate [photo 8].

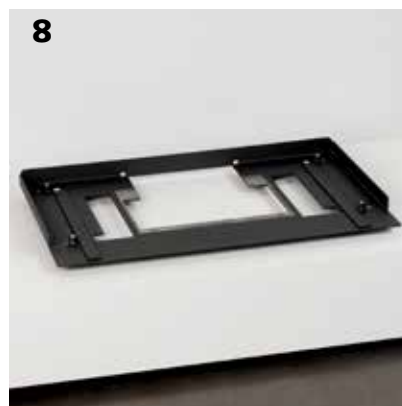
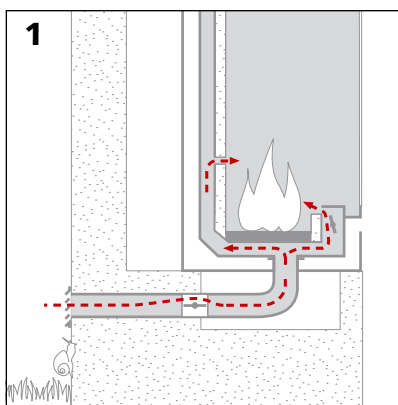

Fan kit

Warning! These components are not compatible with Stûv 16-H and Stûv 16-U configurations.

If you install the Stûv 16-cube on a Stûv base with a drawer, the composition of the ventilation kit and the installation procedure are slightly different.

Please refer to the instructions that come with the base with a drawer.

a fan + 2 screws

b electronic regulator
+ 2 M4 x 8 screws
with hexagonal heads

c switch with 4 positions
+ support
+ finish plate

d cable with 4 wires

e thermal switch
+ cable
+ cable guide

f 2 pre-cut filling plates (to be modified in line with the model of stove) + 4 screws tx M4 x 6



g air-tight seal for convection air circuit with pull thread.

grips, screw holes for attaching the duct)

h auto-adhesive aluminium strip to ensure the air-tightness of the outside envelope (transport handle

Assembly of the fan on the base plate

Remove the covers [photo 2] and get the power cable ready.

Put the fan into position [photo 3].



Electrical connections

Connection of the power supply and earth

Connect the cables to the circuit; the terminal blocks can be disconnected from the electronic circuit [photo 4]. The connection indications are marked on the underside of the terminal blocks (power supply, earth, speed 1, 2,).

Connect the power supply [photo 5-a].

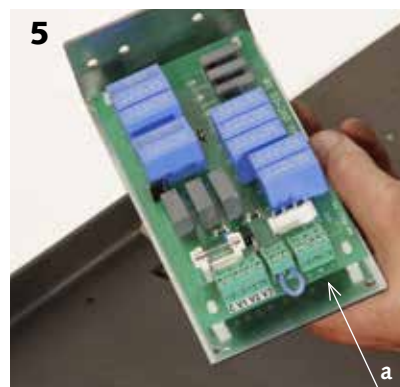
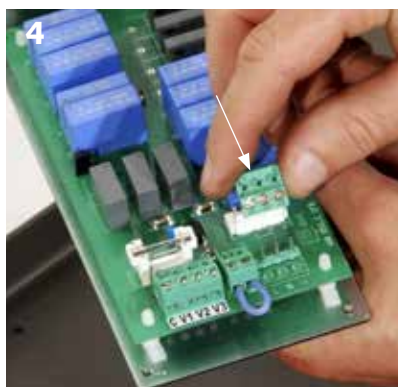

Connect the earth to the circuit's metal support [photo 6].

Connection of speed control

Strip the cable with 4 wires and clean the sheath of each wire; you will see that each of the wires is numbered. Connect to the terminal block [photo 7-c] by following the indications of the wiring scheme [8].

Connection of the fan

The cable attached to the fan is provided with a connector; connect it [photo 7-d].

Test the unit is working before connecting the thermal switch. After testing, turn off the power!

Adjustment of the fan's power

If the ducts [diagram 9] have a considerable length ($A + B > 3m$)*, the fan will require more power to overcome the pressure loss: you will have to connect the 3 separately supplied jumpers to the electronic circuit [photo 10].

* A: Length of the longest aspiration duct

B: Route of the air inside the stove
= 1m

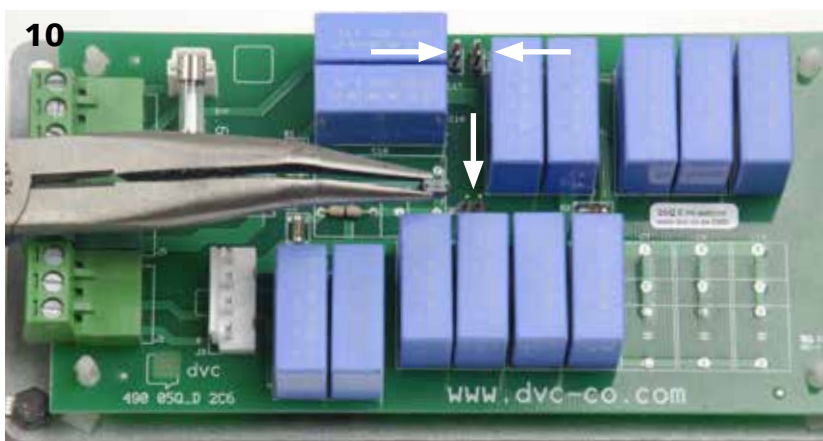
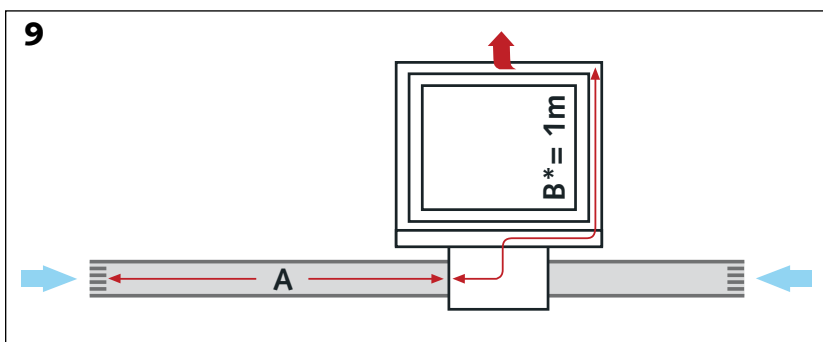
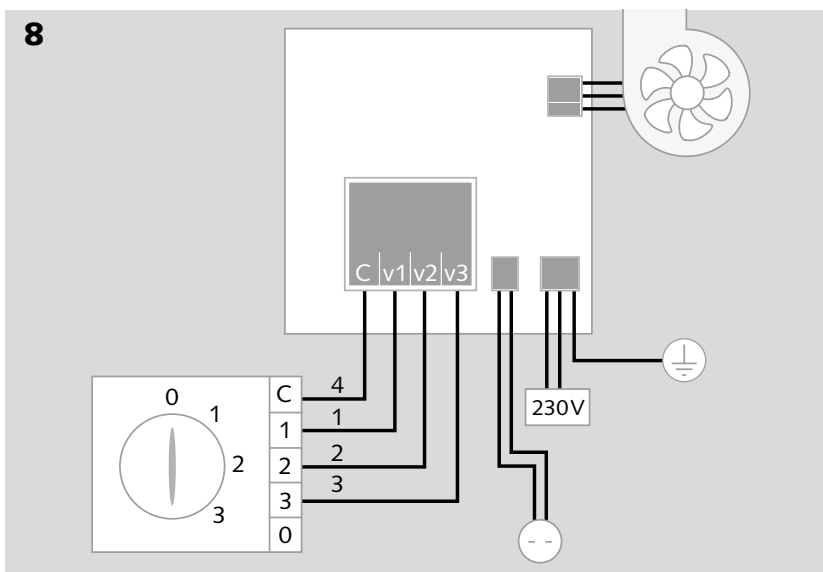
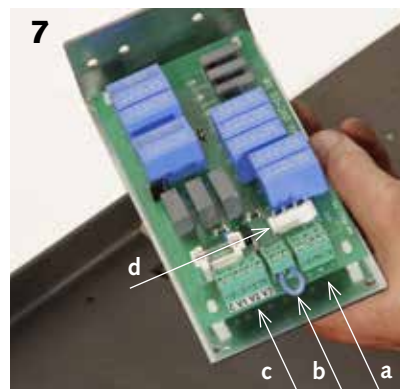
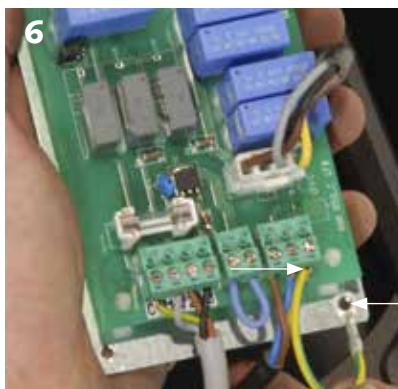

Electrical connections (continued)

Connection of the thermal switch to the electronic circuit

The thermal switch only allows power to the fan when the temperature of the reheated air is high enough. Therefore, when lighting, the fan will only start after a few minutes to prevent unpleasant currents of cold air.

The same applies when putting out.

- Remove the shuntage [photo 12-b].
- Put the cable into the cable guide.
- Connect the thermal switch to the terminals now freed up.
- The thermal switch will later be attached to the stove.

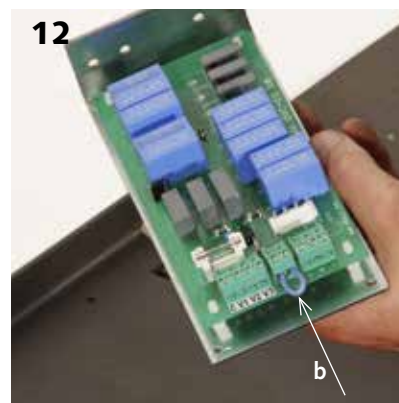

Closing the fan's cover

Attach the electronic circuit under the front part of the access cover to the fan using 2 M4 x 8 screws with hexagonal heads [photo 1].

Position the back part of the access cover [photo 2]. Push the fan right to the back. Attach the back cover at the same time as the side parts [a] forming the mouth of the fan using the 2 M4 x 12 screws.

Close the lateral openings [photo 2-a] using the two filling plates the length of which will have been adjusted to match the stove that you are installing [photo 3]. Attach them using the 4 screws tx M4 x 6.

Connect the air inlet duct to the nozzle [photo 4] and attach the front part of the cover (with the electronic circuit) to the base plate. Ensure the cables of the thermal switch [photo 5-a] pass through the notch provided for this purpose and are protected by a cable guide.

The two closure sections of the fan's cover lock into place the collar of the combustion air adduction duct.

Fix the air-tight seal [photo 5 and 6] to prevent the fan disturbing combustion. Cut the excess with the cutter.

If you have not created an outside air connection, reclose the opening using the filling plate [photo 6-a]

The stove can now be installed on the base plate.

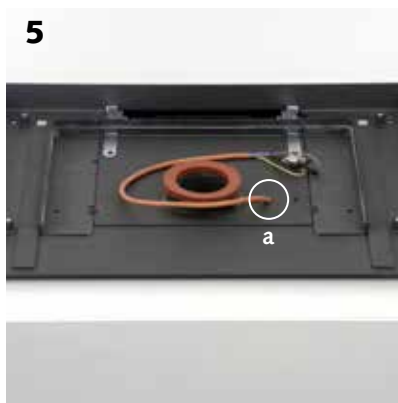
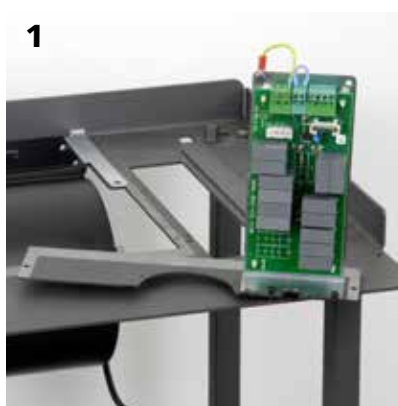

Positioning of the stove

Place the stove onto the plate.

The stove's lug [photo 1-a] must be lowered onto the hole [b] cut in the plate.

Fasten the stove to the plate using screws and nuts [photos 2, 3 and 4].

Put on the cover [photo 5]. The hole cut in the cover should be centred in relation to the stove's smoke outlet.

Attach the cover using the 4 screws at the front [photo 6], starting with the lower screws.

The upper part of the cover has to be fixed to the stove using a bolt provided for this purpose [photos 7 and 8].

Undo the bolt's hexagonal screw [photo 7]

Swivel it 3/4 of a turn [photo 8] and retighten.

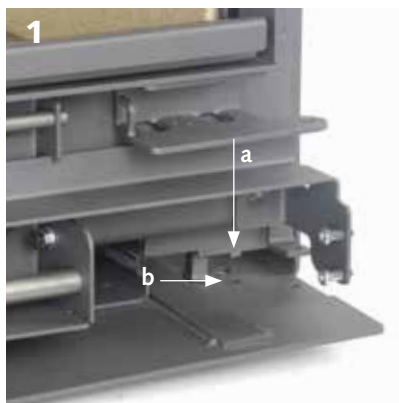

Connection to the smoke flue

To avoid damage to the diverters when sweeping the chimney, we recommend putting the stainless steel bar over the smoke outlet [photo 1].

Simply put the duct into the stove's smoke outlet. Leave a 2 mm gap lengthways to allow for expansion.



Assembly of the thermal switch

If you have not installed a fan, go to the next section.

Push the valve as far left as possible.

Unscrew the valve cap (2 M4x6 screws) [photo 1].

Move the valve cap to the right to bring its notch into line with the slide control [photo 2] to be able to remove it.

Attach the thermal switch temporarily using the screws [photo 2].

Attach the earth ringlet by inserting a washer (provided in the fan kit fittings packet) to ensure good electrical contact [photo 3].

Put the valve cap back on. Right screw, then left screw.

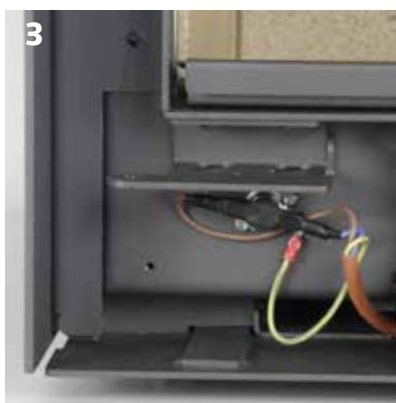

Installation of the panel

The panel is the part which protects the mechanisms in the lower part of the stove [photo 3].

The flap fits onto the stop screw [pic. 4-b] and pivots on the screw [c].

Adjust the screw [pic. 5] on the right-hand side of the flap (holding the magnet) so that:

- the magnet has sufficient force of attraction,
- and that the flap is vertical in a closed position.

The magnet attracts the filings: keep the contact parts clean !

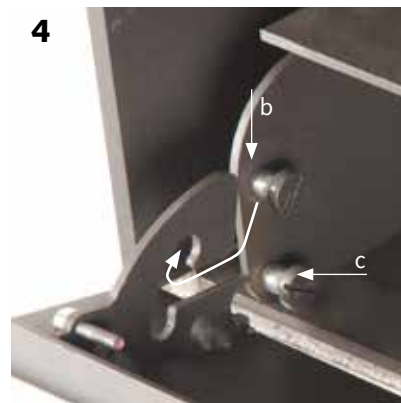

Refitting the door

Refit the door on its hinges.

A spring inside the door shuts it automatically [picture 1] hook up the spring to its lug inside the stove [picture 2].



Graduated tablet

Tilt the flap [picture 1].

Slide in the graduated tablet – adjusted to the centre of the register – under the register hood [picture 2]. It is simply placed on the 2 lateral screws.

Put the back edge of the tablet under the valve cover [photo + diagram 3-a].

The front edge of the tablet is inserted between the front part of the flap [3-b] and the 2 lateral screws [3-c].

Close the flap [picture 4].

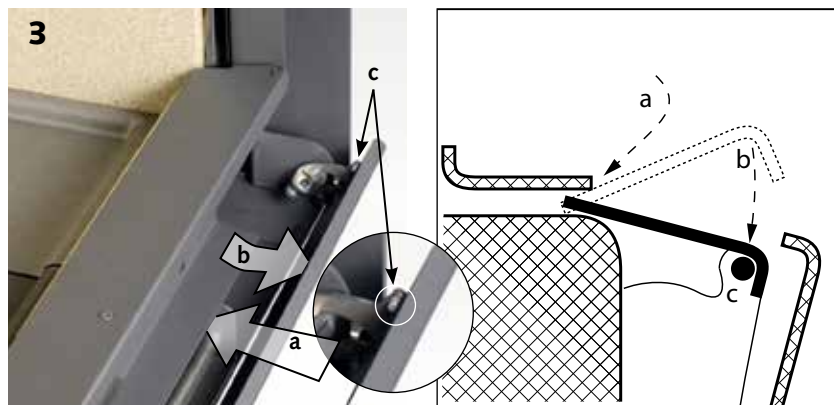

When the installation of the stove is complete...

... Carry out a test to ensure it is working correctly.

Before this test, ensure no items involved in installation have been left in the combustion chamber or in the bends (spray paint, tubes of grease, tools).

When the fire is first lit, some smoke or odours may be produced: Ventilate the room thoroughly.

See directions for use.

Once installation is complete, return the directions for use to the user. Fill in the guarantee certificate with him (at the back of the directions for use) and advise him to return it to the manufacturer or importer.

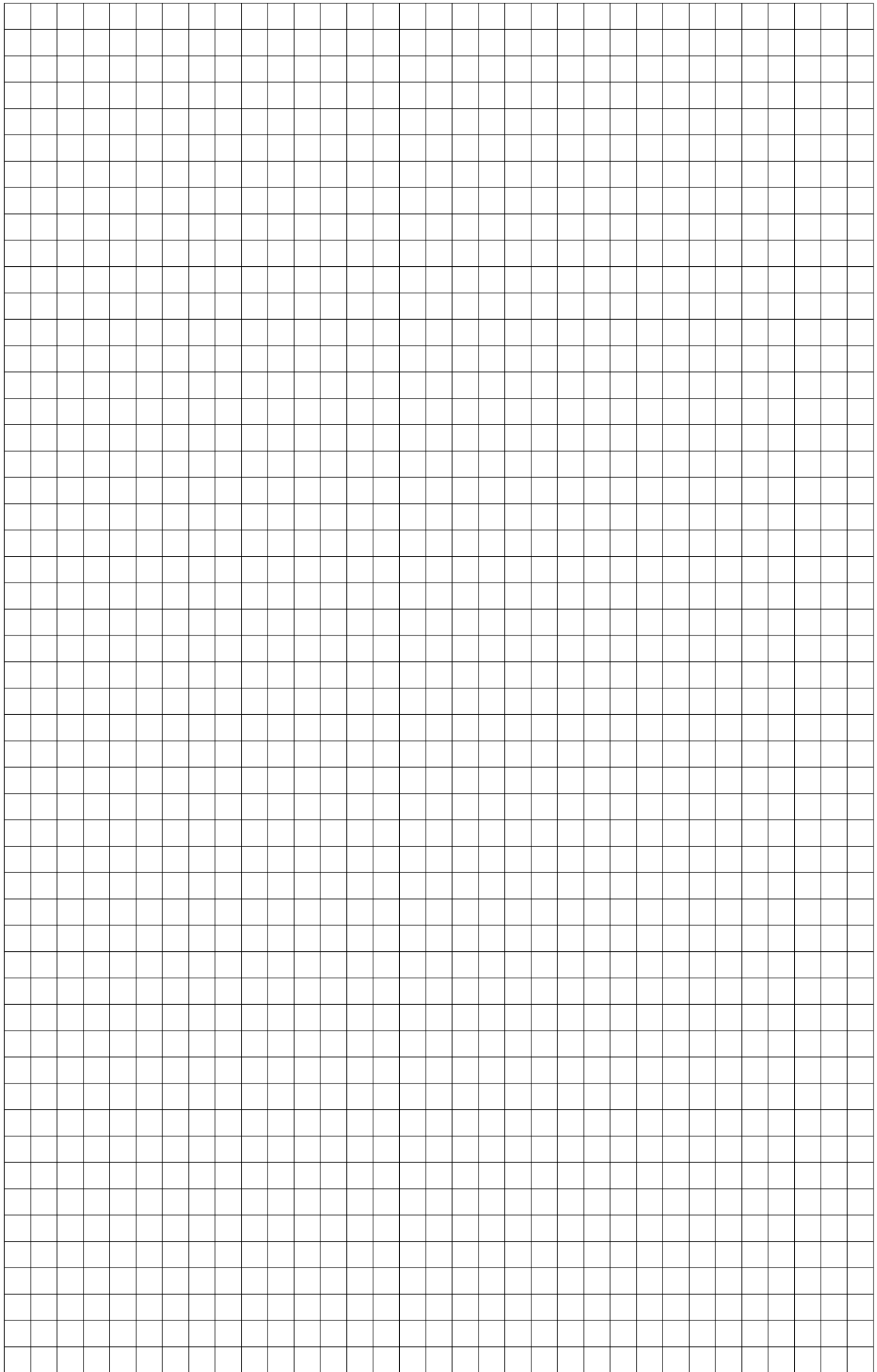

ACCEPTANCE OF WORKS



PLEASE COMPLETE IN BLOCK CAPITALS.

THE PURCHASER

SURNAME
FIRST NAME
ADDRESS WHERE WORKS WERE CARRIED OUT
POST CODE
TOWN/PLACE
COUNTRY

INSTALLATION ENGINEER

COMPANY

YOUR STÛV STOVE 16-CUBE OR STÛV 16-H

SERIAL N°
DATE OF INSTALLATION

FLUE CHARACTERISTICS

HEIGHT OF FLUE IN M
DIAMETER OF FLUE IN MM
TYPE OF FLUE

CHECK OF SYSTEM'S SETTINGS

CHECK ON THE VACUITY OF THE FLUE
VALIDATION OF DRAUGHT
VERIFICATION OF AIR INLET SETTING
(OPEN/CLOSED)

CHECK OF THE HUMIDITY OF THE WOOD HUMIDITY % NO WOOD

COMMENTS
.....
.....

SAFETY GUIDELINES

The use of this system has to comply with the installer's recommendations and the manufacturer's instructions which are set out in the directions for use issued to the customer with the invoice and this confirmation of acceptance.

The efficiency and longevity of the system depend directly on the quality of wood used: it is essential that wood with humidity of less than 18% or reconstituted wood briquettes are used. Green wood with drying-out time of less than 24 months cannot be used (more information in the "fuels" section on pages 8 and 9 of the directions for use).

THE INSTALLATION ENGINEER (name written out in full and signature).....

THE CUSTOMER (name written out in full and signature)

Directions for use of the system issued to customer / Information sheet on lighting the stove issued to the customer

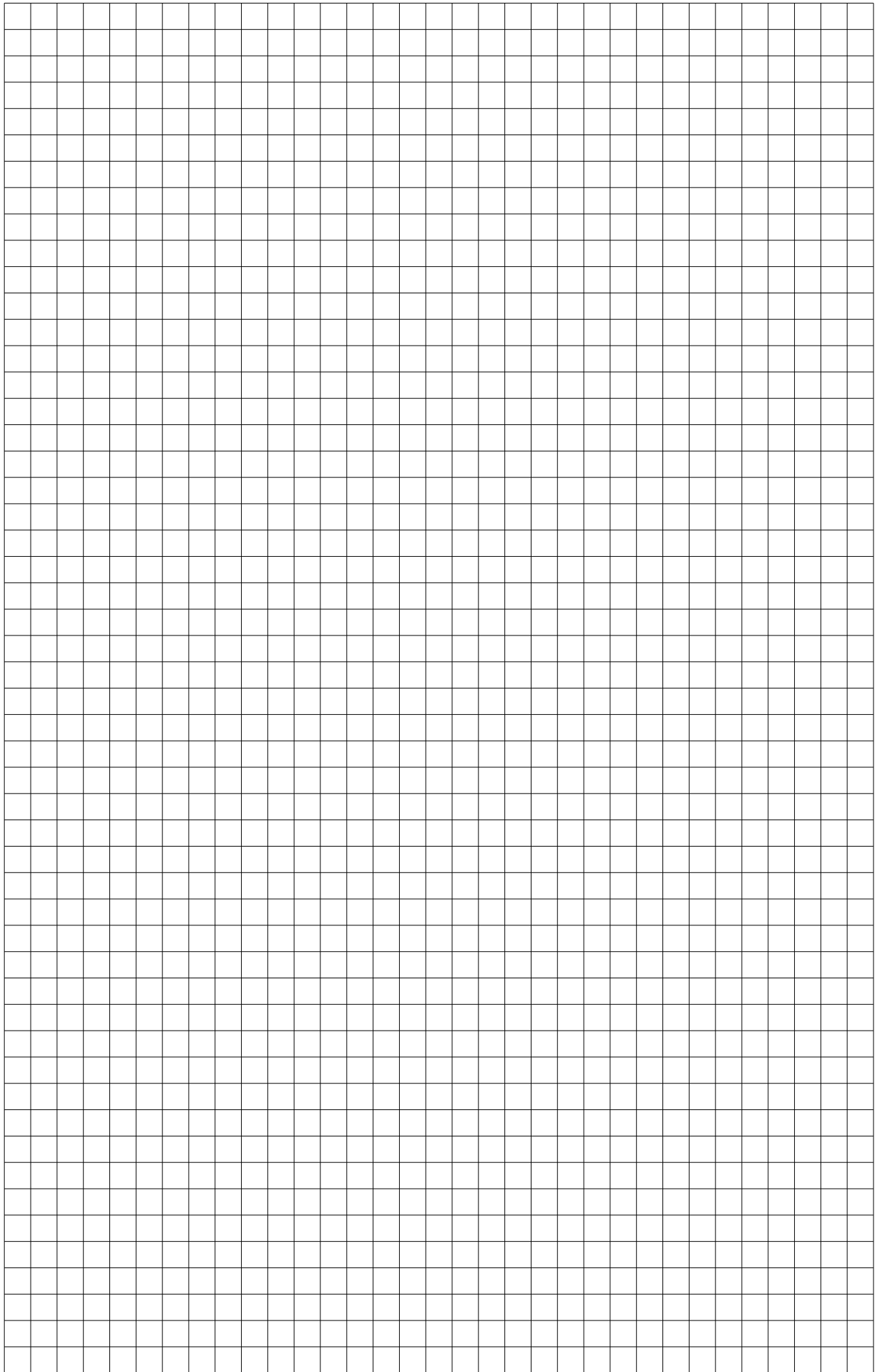

CONTACTS

Stûv stoves are designed and manufactured in Belgium by:

Concept & Forme sa
rue Jules Borbouse 4
B-5170 Bois-de-Villers (Belgium)
info@stuv.be – www.stuv.be

Importer for the UK

Jet Master Fires Ltd – Unit 2
Peacock trading Estate, Goodwood Rd
S050 4NT Eastleigh – Hampshire
T 0870 727 0105
jetmastersales@aol.com
www.jetmaster.co.uk

Importer for Finland

Ilkka Alatarvas OY
Pikkujärventie 4B
01680 Vantaa
T 400 872 858
www.takkamaailma.com

Importer for Sweden

Eldoform Sverige AB
Slipgatan 2 – 117 39 Stockholm
T 0707 883 53 – www.eldoform.se

Importer for Denmark

Stove APS
Aldershvilevej 84 – 2880 Bagsvaerd
T 51 33 10 93

Importer for Estonia

Tulering Kaminasalong Oü
Sopruse 145 – 13417 Tallinn
T +372 56 249 004 - www.tulering.ee



printed on 100% recycled paper

installation instructions [en] Stûv 16-cube & Stûv 16H

05-2013 – SN 97951 > ...



Stûv reserves the right to make changes without prior notice.
These instructions have been produced with the greatest of care.
However, we do not accept responsibility for any errors that may have been made.
Editor: Gérard Pitance – rue Jules Borbouse 4 – 5170 Bois-de-Villers – Belgium

[nl] [de] [it] [es] [pt] [cz] [en] [fr] >
This document is available in several
languages: Contact your distributor or visit
www.stuv.com